

## COMPRESSED AIR BALL FLOAT TRAPS FA17G (DN 40 – DN 50)

### DESCRIPTION

The FA17G series are fully automatic ball float traps, extremely compact in dimension and light in weight, specially designed for draining water from compressed air lines. Usual applications include aftercoolers, separators and compressed air mains.

### MAIN FEATURES

Modulating discharge.  
Unaffected by sudden or wide load and pressure changes.

OPTIONS: Horizontal reversible inlet connections.

USE: Compressed air and non corrosive gases compatible with the construction.

AVAILABLE MODELS: FA17G.

SIZES: 1 1/2" to 2"; DN 40 to DN 50.

CONNECTIONS: Female threaded ISO 7 Rp.  
Flanged EN1092-2 PN16 or ANSI Class 150 lb.

INSTALLATION: Standard horizontal installation – flow from right to left (R-L).  
Vertical installation with the flow from top to bottom (V).  
See IMI – Installation and maintenance instructions.



APPLICATION LIMITS	
Min. liquid specific weight	0,75 kg/dm <sup>3</sup>
Maximum working diff. pressure	14 bar

CE MARKING – GROUP 2 (PED – European Directive)	
PN16	Category
1 1/2" to 2" – DN 40 to 50	SEP

BODY LIMITING CONDITIONS		
FLANGED PN16 *	FLANGED ANSI 150 lb **	RELATED TEMPERATURE
ALLOW. PRESS.	ALLOW. PRESS.	
16 bar	15,4 bar	100 °C
15,5 bar	14,6 bar	150 °C
14,7 bar	13,8 bar	200 °C
13,9 bar	12,1 bar	250 °C

PMO – Max. operating press. 14 bar;

TMO – Max. operating temp. 200 °C;

\* According to EN1092-2:2007; \*\* According to EN1759-1:2004;

Body limiting conditions PN16 or below, depending on the type of connections adopted. Rating PN16 for thread, SW and BW.

FLOW RATE CAPACITY (kg/h)														
MODEL	SIZE	DIFFERENTIAL PRESSURE (bar)												
		0,5	1	1,5	2	3	4	6	7	8	9	10	12	14
FA17G	1 1/2" to 2"; DN 40 to 50	370	515	605	720	900	1005	1250	1340	1500	1560	1620	1750	1890

**DIMENSIONS (mm)**

SIZE	THREADED							PN16			ANSI 150 lb		
	A	B	C	D	E	H	WEIGHT (kg)	F	B	WEIGHT (kg)	F	B	WEIGHT (kg)
1 1/2" - DN 40	210	248	79	208	131	1/4" NPT	16,9	230	248	20,3	230	248	19,1
2" - DN 50	210	248	79	208	131	1/4" NPT	17,5	230	248	20,7	230	248	20,5

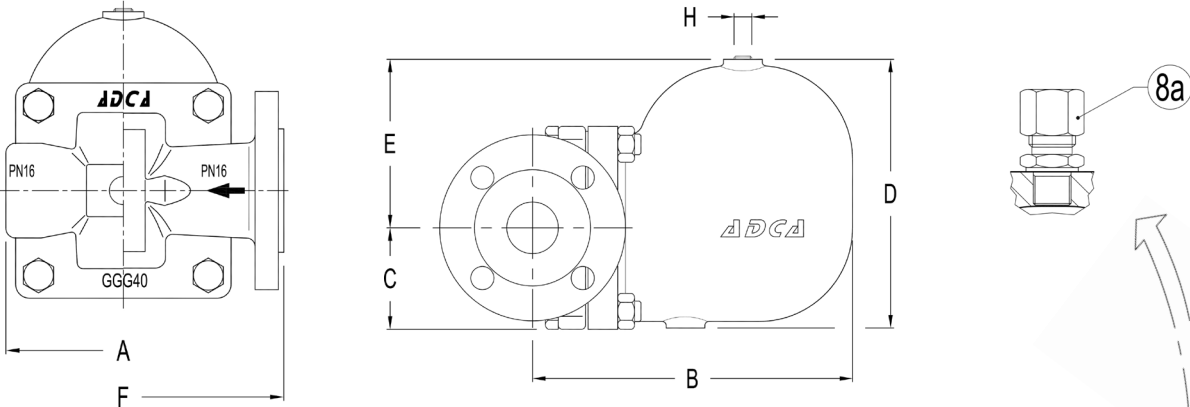

**MATERIALS**

POS. N°	DESIGNATION	MATERIAL
1	Body	GJS-400-15 / 0.7040
2	Cover	GJS-400-15 / 0.7040
3	* Gasket	Stainless steel / Graphite
4	* Seat	AISI 304 / 1.4301
5	* Valve	AISI 304 / 1.4301
6	* Lever	AISI 304 / 1.4301
7	* Float	AISI 304 / 1.4301
8	Plug	Stainless steel
8A	** Compression fitting	Stainless steel or Steel Fe/Zn
9	Bolts	Steel 8.8

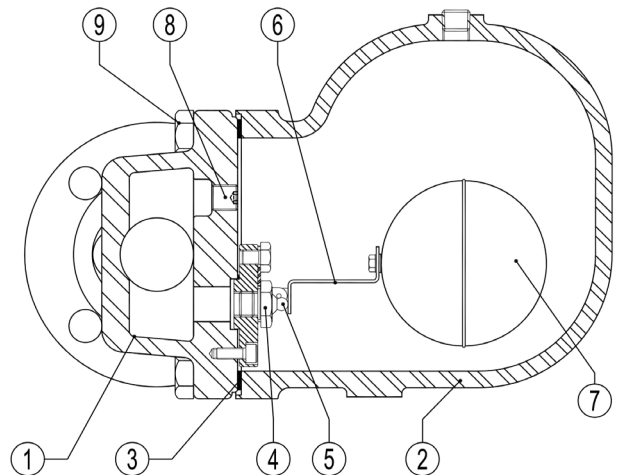

\* Available spare parts.

\*\* Optional, against extra price.

**TYPICAL INSTALLATION**

